

CRACK FROM 1/16 TO 1/2 INCH (1-13mm)

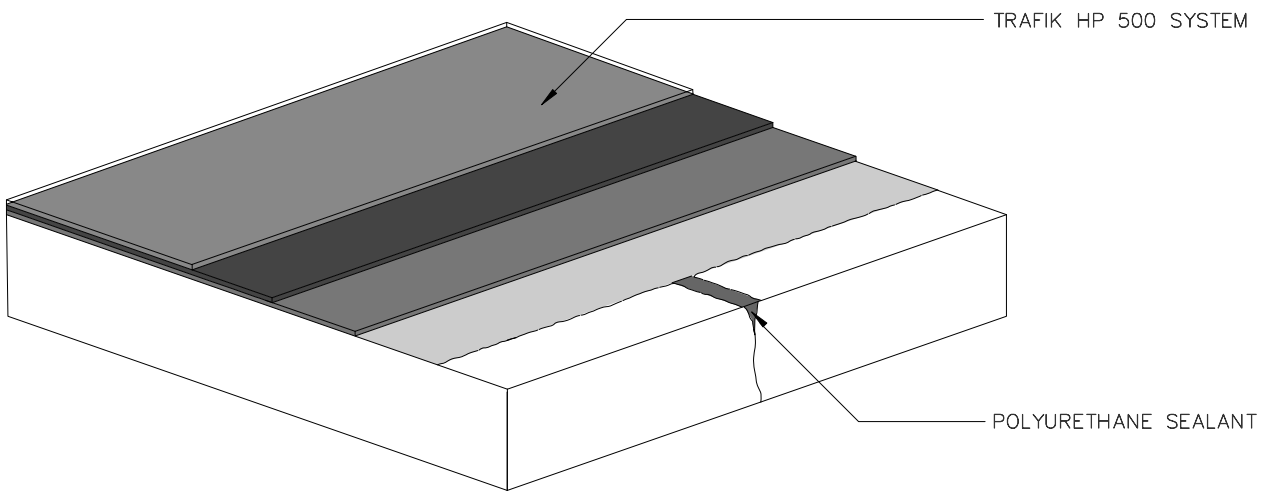

NOTE:

1. ROUT OUT MINIMUM 1/4 INCH (6mm) WIDE AND FILL WITH POLYURETHANE SEALANT.

CRACK FROM 1/2 TO 1 INCH (13-25mm)

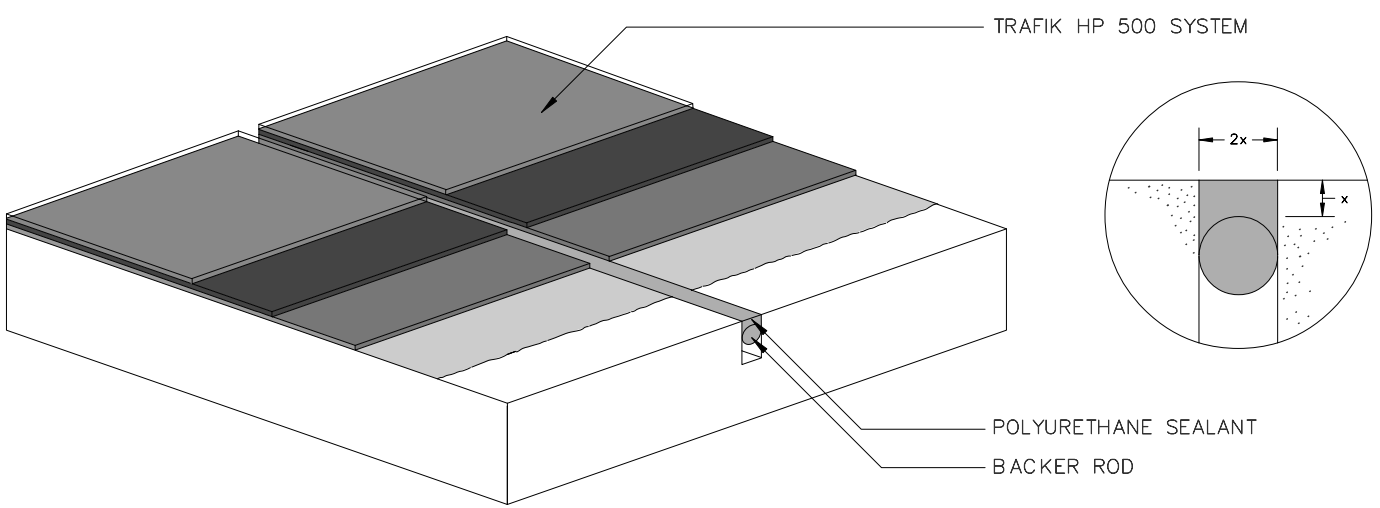

NOTES:

1. JOINT SHOULD BE DESIGNED SO THAT POLYURETHANE SEALANT HAS A 2:1 WIDTH/DEPTH RATIO MEASURED FROM THE TOP OF THE BACKER ROD.
2. DO NOT EXCEED 1/2 INCH (13mm) IN DEPTH.

NOTES:

1. DETAIL TO BE USED IN CONJUNCTION WITH SOPREMA GENERAL REQUIREMENTS, APPLICATION METHODS AND APPROVED DETAILS.

		310 QUADRAL DRIVE WADSWORTH, OHIO 44281 (330) 334-0066					
		TITLE ALSAN TRAFIK HP 500 CRACK PREPARATION					
SCALE	NONE	DWN	PBF	CHK	SR	APPROVAL DATE	4/2/09
DRAWING NUMBER		T-2			REV		0

** USAGE OF THIS DRAWING IS GOVERNED BY THE TERMS OF SERVICE FOR SOPREMA DETAIL. PLEASE CONSULT THESE TERMS OF SERVICE PRIOR TO UTILIZING THIS DRAWING.