

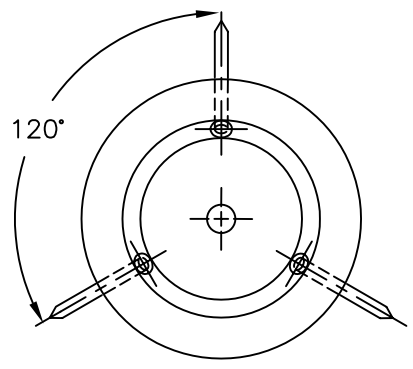

←TRI-FIXX PLATE CENTERED IN 5" (12.7cm) MINIMUM SIDE LAP. FULLY WELD AROUND→
 MEMBRANE PLATE, LAP IS HOT AIR WELDED OR UNROLLED AS THE LAP IS BEING HEAT WELDED.

SEE NOTE 2.

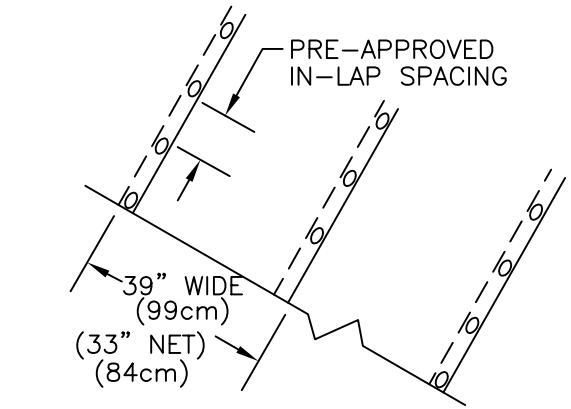
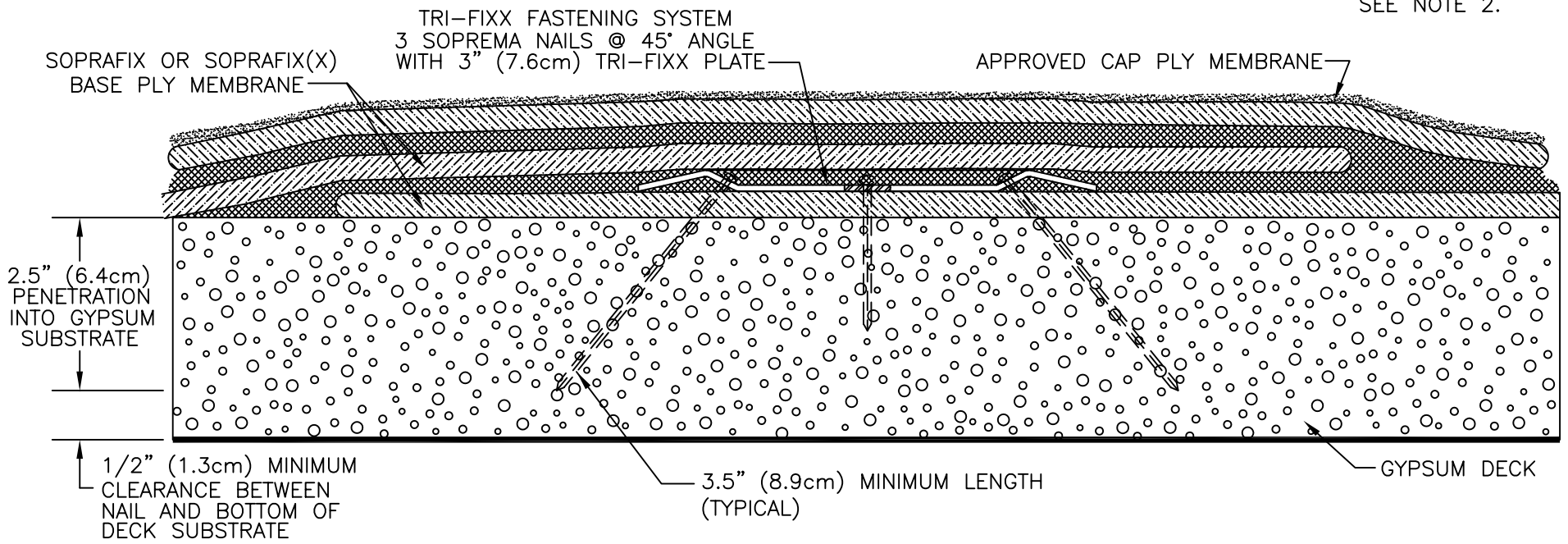

- NOTES:
1. DETAIL TO BE USED IN CONJUNCTION WITH SOPREMA GENERAL REQUIREMENTS AND APPROVED DETAILS.
 2. FOR WIND WARRANTY RIDERS GREATER THAN 63 MPH; IT IS THE SOLE RESPONSIBILITY OF THE ROOFING CONTRACTOR TO OBTAIN PRE-BID AND/OR PRE-JOB START-UP APPROVED FASTENING PATTERNS FROM SOPREMA'S CORPORATE TECHNICAL DEPARTMENT. IF APPROVAL IS NOT OBTAINED PRIOR TO INSTALLATION, THE COST OF INSTALLING ADDITIONAL FASTENERS WILL BE BORNE BY THE RESPONSIBLE PARTY.
 3. PERIMETER DEFINITION: $X=4/10$ OF BUILDING HEIGHT OR $1/10$ THE BUILDING WIDTH, WHICHEVER IS THE LESSER DIMENSION, WITH A MINIMUM OF 3 PERIMETER ROLLS ON PROJECTS WITH WIND EQUAL TO OR LESS THAN 63 MPH @ 3 SEC GUST. THE NUMBER OF PERIMETER ROLLS AND FASTENER DENSITIES WILL INCREASE WHEN SPECIAL WIND WARRANTY RIDERS ARE APPROVED.
 4. SOPREMA DETERMINES FASTENING PATTERNS BASED ON PULL-OUT VALUES

		310 QUADRAL DRIVE	
		WADSWORTH, OHIO 44281	
		(330) 334-0066	
TITLE TRI-FIXX LAP CROSS SECTION - GYPSUM			
SCALE	DWN	CHK	APPROVAL DATE
NONE	DMT	PR	10/15/04
DRAWING NUMBER TFMA-002			REV 0

** USAGE OF THIS DRAWING IS GOVERNED BY THE TERMS OF SERVICE FOR SOPREMA DETAIL. PLEASE CONSULT THESE TERMS OF SERVICE PRIOR TO UTILIZING THIS DRAWING.